

REV	DESCRIPTION	ECN #	CHG BY	DATE	APP'D
A	CONVERTED TO 3D		NAS	06/24/19	NAD
B	UPDATED DRAWING STYLE	17585	TAS	11/04/19	NAD

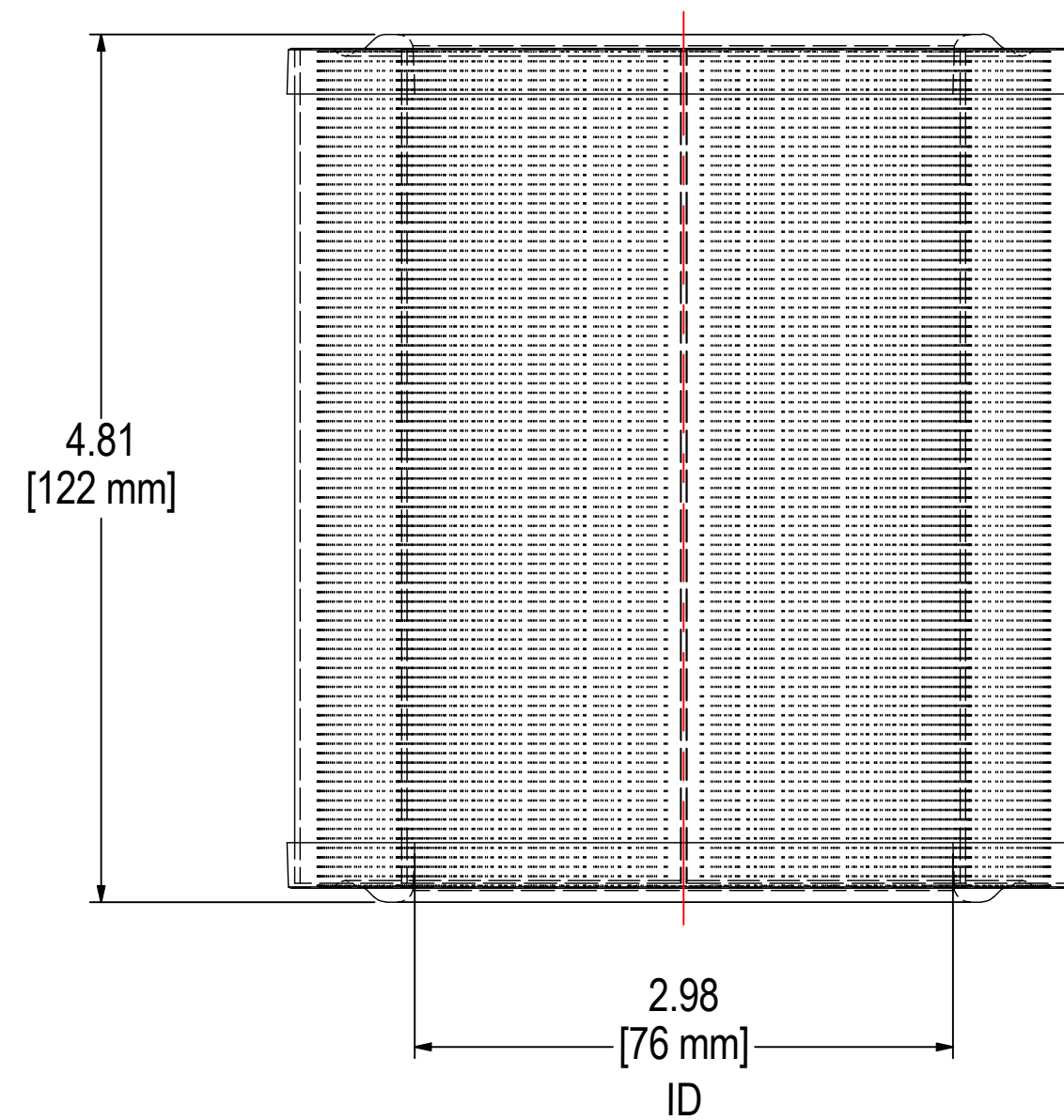
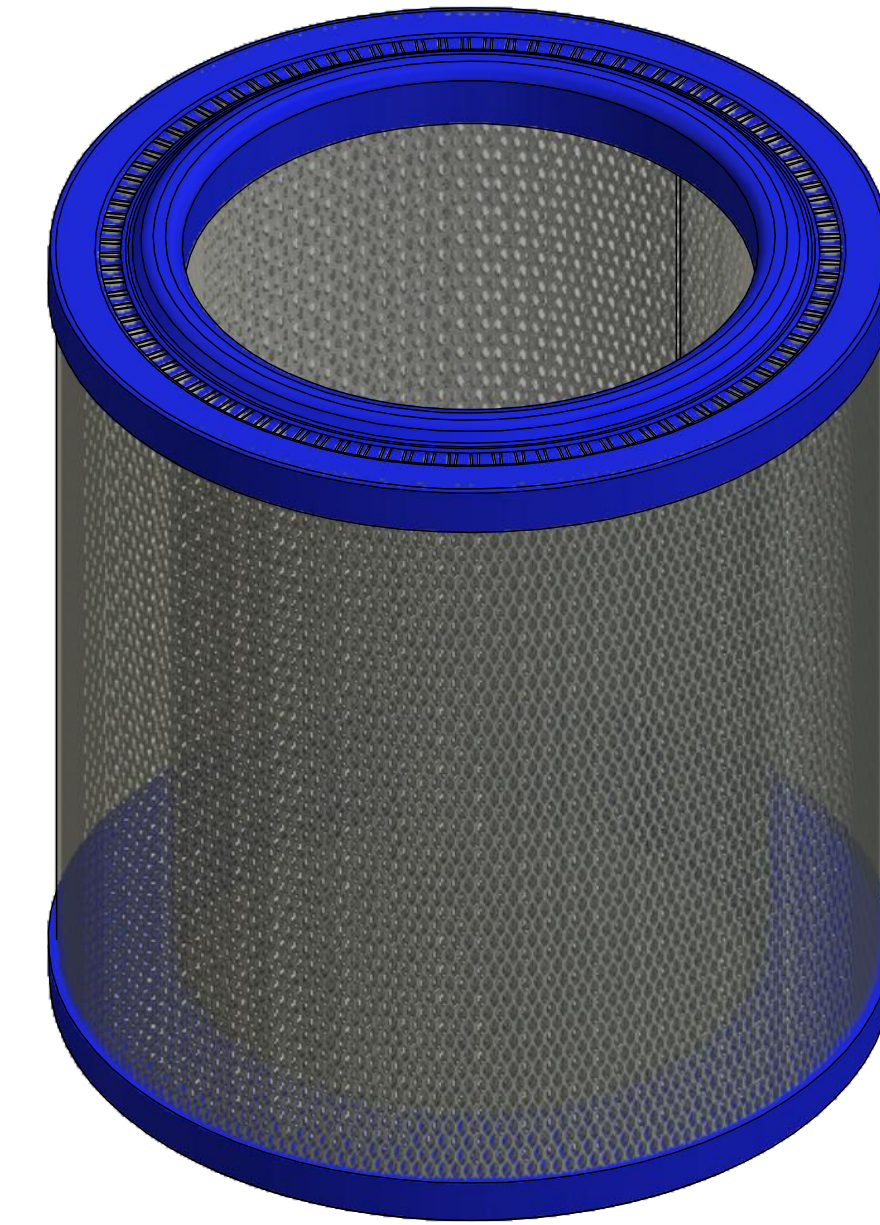
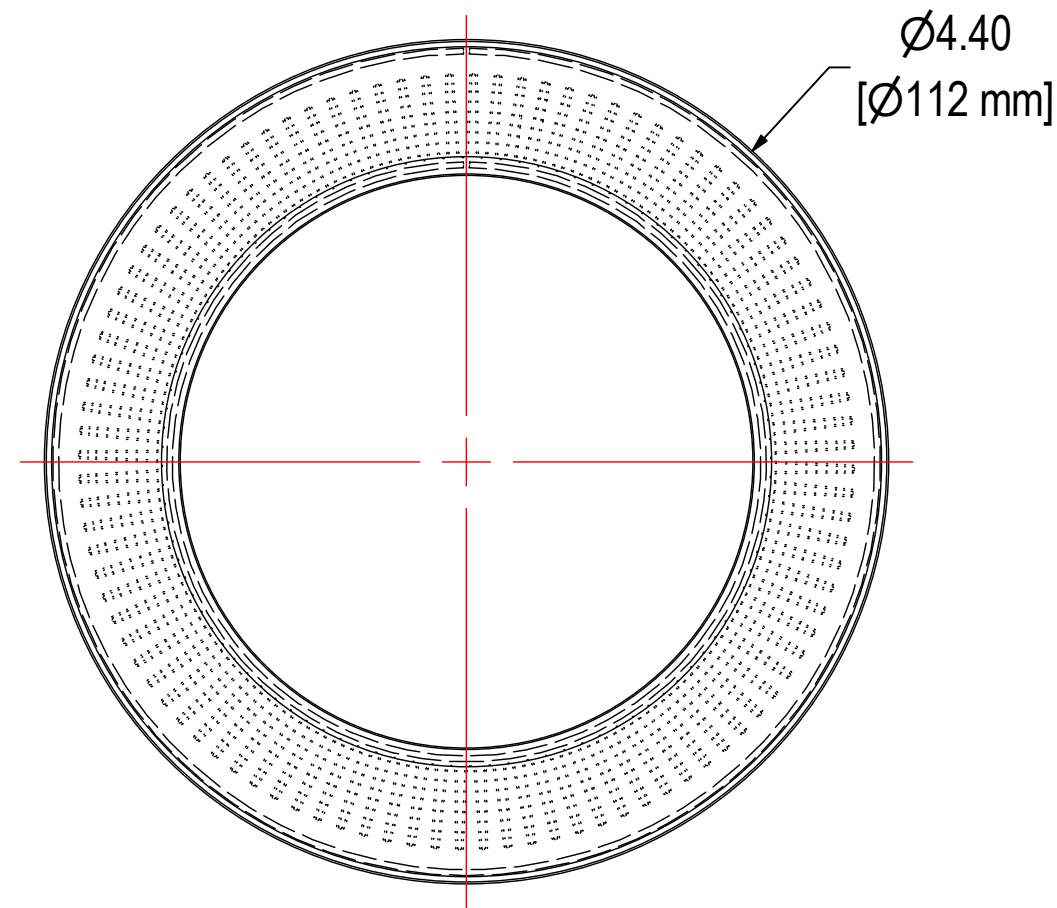

ELEMENT SPECS		
PART NUMBER	18	
MATERIAL	PAPER	
FLOW RATE	100 CFM	170 m ³ /hr
SURFACE AREA	2.6 ft ²	0.2 m ²
I.D.	2.98"	76mm
O.D.	4.40"	112mm
HEIGHT	4.81"	122mm